

#### Specifications

Nominal Voltage		12 V
Rated capacity(10HR)		150Ah
Dimension	Length	485 ± 2mm (19.09inch)
	Width	172 ± 2mm (6.77inch)
	Height	240 ± 2mm (9.45inch)
	Total Height	240 ± 2mm (9.45inch)
Approx. Weight		44.0kg (96.8lbs) ± 3%

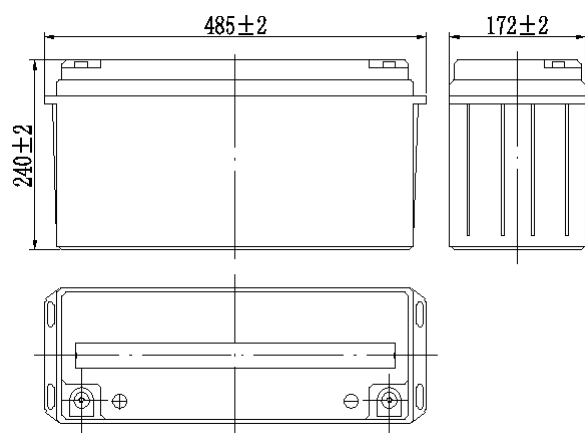

#### Dimensions



#### Terminal

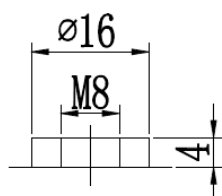

#### Characteristics

Capacity (25°C)	10HR(10.8V)	150 Ah
	3HR(10.8V)	112.5Ah
	1HR(10.5V)	85Ah
Terminal type		T16
Internal resistance (Fully charged, 25°C)		Approx. 4mΩ
Capacity affected by temperature (10HR)	40°C	102%
	25°C	100%
	0°C	85%
	-15°C	65%
Self-discharge (25°C)	3 month	Remaining Capacity: 91%
	6 month	Remaining Capacity: 82%
	12 month	Remaining Capacity: 65%
Nominal operating temperature		25°C ± 3°C (77°F ± 5°F)
Operating temperature range	Discharge	-15°C ~ 50°C (5°F ~ 122°F)
	Charge	-10°C ~ 50°C (14°F ~ 122°F)
	Storage	-20°C ~ 50°C (-4°F ~ 122°F)
Float charging voltage(25°C)		13.50 to 13.80V Temperature compensation: -18mV/°C
Cyclic charging voltage(25°C)		14.50 to 15.00V Temperature compensation: -30mV/°C
Maximum charging current		45A
Terminal material		Copper
Maximum discharge current		1200A(5 sec.)
Designed floating life(20°C)		10 years

#### Construction

Component	Positive plate	Negative plate	Container	Cover	Separator	Electrolyte	Safety valve	Terminal
Raw material	Lead dioxide	Lead	ABS	ABS	AGM	Sulfuric acid	Rubber	Copper

#### Constant Current Discharge Characteristics (A, 25°C)

F.V/TIME	10min	15min	30min	60min	2h	3h	4h	5h	8h	10h	20h
9.60V	327	252	151	92.7	54.8	39.5	31.5	26.9	18.5	15.3	8.09
9.90V	317	246	148	91.3	54.5	39.2	31.3	26.8	18.4	15.2	8.08
10.2V	304	237	143	89.0	54.0	39.0	31.1	26.6	18.3	15.2	8.05
10.5V	291	229	140	86.2	53.2	38.7	30.9	26.4	18.2	15.1	8.01
10.8V	275	217	135	83.4	51.8	37.5	30.0	25.6	17.6	15.0	7.95

#### Constant Power Discharge Characteristics (Watt, 25°C)

F.V/TIME	10min	15min	30min	60min	2h	3h	4h	5h	8h	10h	20h
9.60V	3532	2767	1691	1057	635	464	371	318	220	182	97.1
9.90V	3426	2701	1658	1041	631	461	368	316	219	182	96.9
10.2V	3284	2601	1607	1015	625	458	366	314	217	181	96.6
10.5V	3143	2512	1568	983	616	455	363	312	216	180	96.1
10.8V	2967	2380	1510	951	600	441	352	303	209	179	95.4

Note: The above characteristics data can be obtained within three charge/discharge cycles.

## Deep Cycle AGM Batteries

Discharge Characteristics(25°C)

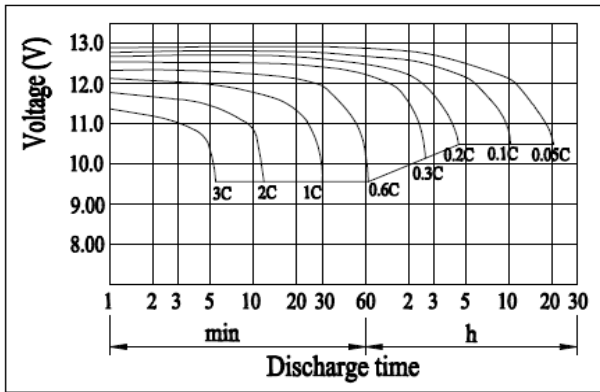

Charging Characteristics(25°C)

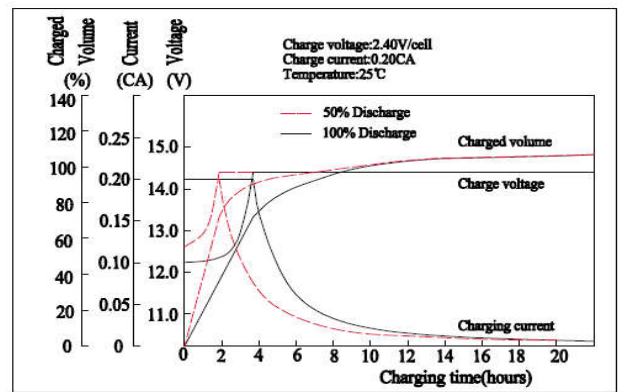

Effect of Temperature on Capacity

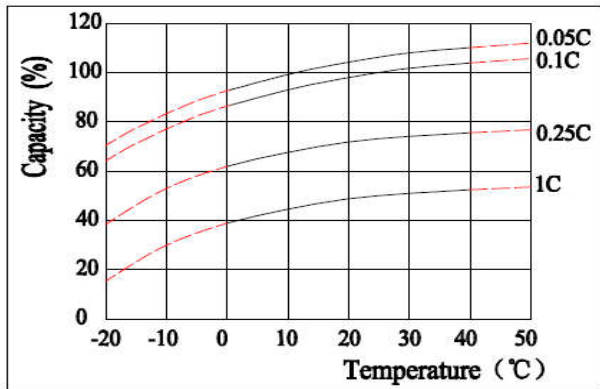

Self-discharge Characteristics

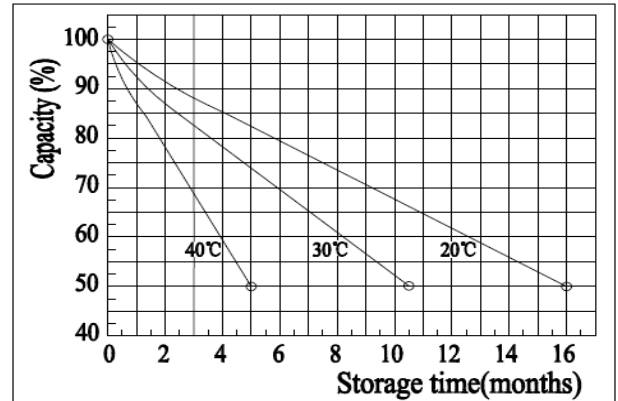

Floating Life on Temperature

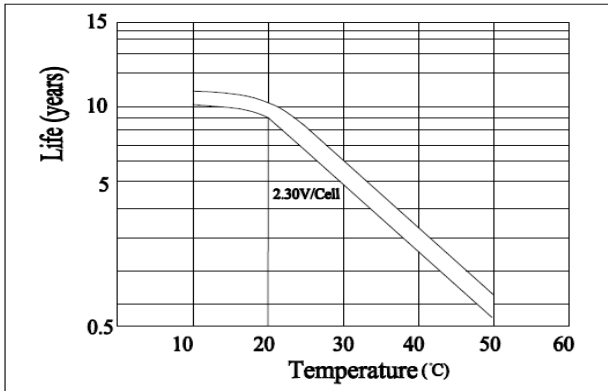

Cycle Life on D.O.D(25°C)

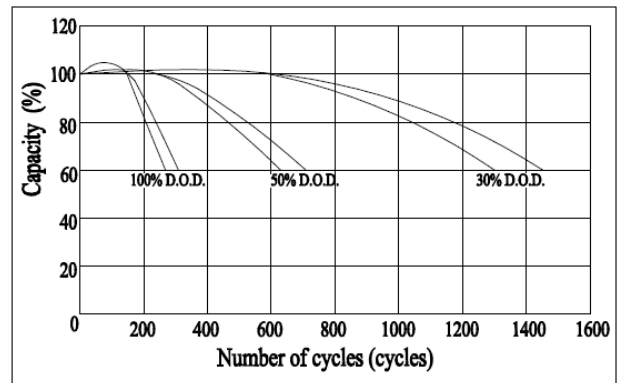

The Relationship for Open Circuit Voltage and Residual Capacity (25°C)

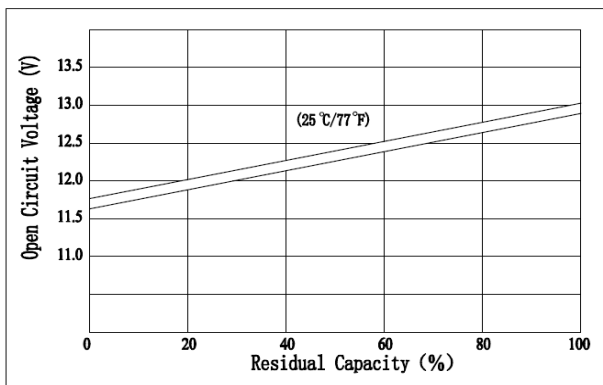

The Relationship for Charging Voltage and Temperature

